

# Acclaim Fresnel 6°-60°

The Acclaim Fresnel is a 575w/650w general purpose Fresnel (110mm diameter lens) for theatre, small studio and display lighting applications which produces an adjustable cone of light with a soft edge that is easily blended with adjacent beams to provide even illumination.

The Acclaim Fresnel is built Selecon tough from aluminium extrusion and moulded engineering plastics – robust, dependable, safe and easy-to-rig – backed by the unique Selecon 3-year warranty for entertainment fixtures.



## Features

- Up to 40% more light output than other Fresnels
- A wide range of beam angles from 6° - 60°
- Integrated safety bond, rated for the fitting; maximum free length = 650mm
- Improved filter life through increased airflow
- Cooler focus operation due to the use of engineering plastics on front (colour frame mount) and rear
- Adjustable yoke balance point
- 'Swing-down' side door for easy access to lamp or for cleaning. Micro-switch automatically isolates the power supply when opened. Lamps are quickly and safely removed using ejector mechanism
- Lamp life is enhanced through judder-free focus action of the captive lamp/reflector assembly which moves on Teflon-coated bearings
- Heat-insulated rear grab-handle which doubles as handy storage for the 1m cable length
- New barndoor design, cool to focus maintaining settings through unique hinge tension design - retro-fittable
- Focusing is fast and safe using the large rear grab handle and heat-protected focus knob and filter holder

**PHILIPS**  
**Selecon**

## SPECIFICATION SUBMITTAL

CONSULTANT <input type="text"/>	PROJECT NAME: <input type="text"/>	MODEL NUMBER   QUANTITY: <input type="text"/> <input type="text"/> <input type="text"/> <input type="text"/> <input type="text"/> <input type="text"/>
DATE: <input type="text"/>	PROJECT NUMBER: <input type="text"/>	APPROVED BY: <input type="text"/>

## Photometric Data

Tests conducted using a standard T27, 650w, 230V, 15,000 lumens lamp.

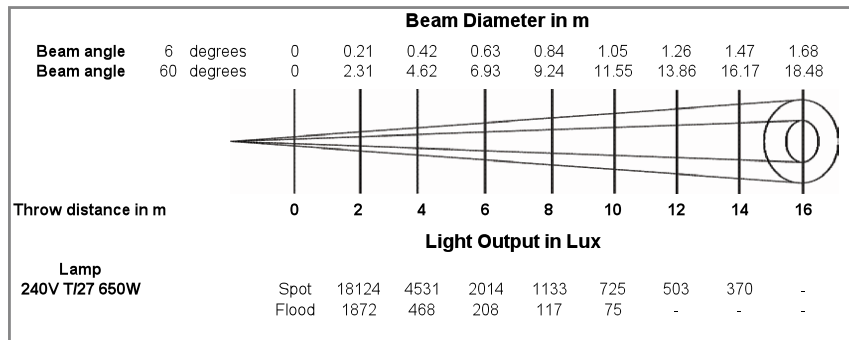

## Lamps

<b>T/25 500w</b>	11,000 lumens, 400hrs average life
<b>M40 500w</b>	10,000 lumens, 2000hrs average life
<b>T/27 650w</b>	14,500 lumens, 600hrs average life

## Approvals

CE marked for use by all, not just professionals

## Physical Data

<b>Weight:</b>	3.3kg
<b>Packed:</b>	3.7kg
<b>Carton Size:</b>	420 x 225 x 175
<b>Cubic:</b>	0.016
<b>Colour Frame Size:</b>	125mm x 125mm
<b>Included:</b>	1x colour frame, 1x M12 nut & bolt set and instruction leaflet

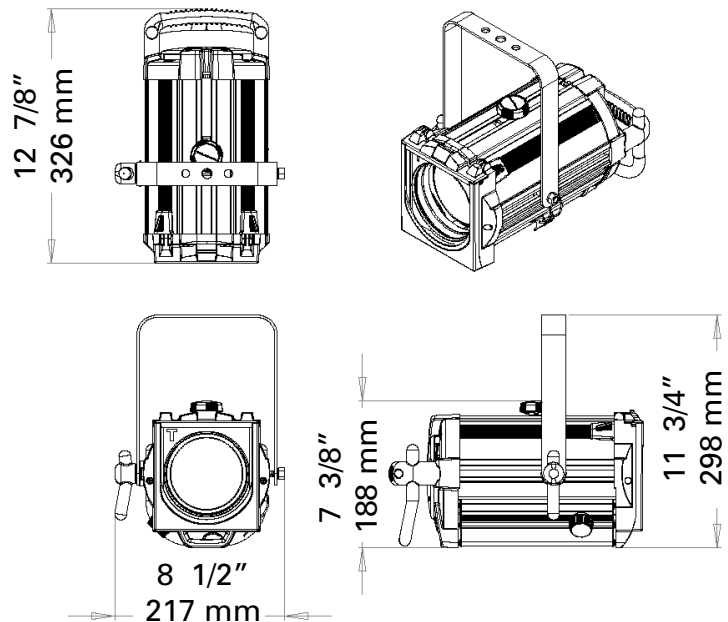

## Ordering Information

**Cat No**      **Description**

<b>12ACFMS</b>	Acclaim Fresnel	<b>20HC</b>	Suspension hookclamp
<b>20BDMF</b>	4 way Barndoor		
<b>15ACSM</b>	Lens safety mesh		

## Philips Selecon

### Los Angeles

6603 Darin Way  
Cypress, CA 90630  
Tel: (714) 230-8200  
Fax: (714) 899-0042

### New York

267 5th Ave, 4th Floor  
New York, NY 10016  
Tel: (212) 213-8219  
Fax: (212) 532-2593

### Dallas

10911 Petal Street  
Dallas, TX 75238  
Tel: (214) 647-7880  
Fax: (214) 647-8030

### www.seleconlight.com

© Philips Group 2009  
All rights reserved.  
The Company reserves the right to make any variation in design or construction to the equipment described. E&OE

### Auckland

19-21 Kawana Street  
Northcote, Auckland 0627  
New Zealand  
Tel: + 64 9 481 0100  
Fax: + 64 9 481 0101

### Asia

Room 6-10,  
20/F Delta House  
3 On Yiu Street  
Shatin, N.T. Hong Kong  
Tel: + 852-2757-3033  
Fax: + 852-2757-1767

### Europe

European Service & Distribution Centre  
Marssteden 152  
Enschede 7547 TD  
The Netherlands  
Tel: +31-53-4500424  
Fax: +31-53-4500425

062409EU