

Arena High Performance Fresnel 9°-52°

The Arena High Performance Fresnel – 2.0kW/2.5kW Fresnel luminaire using a 250mm lens. Beam quality is excellent with a well-controlled flat even field with a distinct “white-blue” tint.

The Arena High Performance Fresnel offers superior light output, strength and industry leading performance.



Features

- Leading performance for a theatre Fresnel due to 250mm diameter lens
- Wide range of beam angles from 9° to 52°
- Integrated safety bond rated for the luminaire
- “Cool Touch Technology” – rear mouldings and large rear grab handle
- Flat even beam with very little spill allows clean masking with barndoor flaps
- Adjustable yoke balance point
- ‘Swing-down’ door for easy access to lamp or lens. Integral micro-switch provides automatic disconnection of power to the fixture when opening to re-lamp, preventing a student or technician inserting a lamp into an electrically live fixture
- Your choice of GY16 lamp socket for CP72, 2.0kW lamp or G22 lamp socket for CP91 2.5kW or CP92 2.0kW lamp
- Smooth focus movement from ‘Posi-slide’ focus system, no metal to metal contact
- Effective airflow maintains lower body temperature
- Constructed of pressure die-castings and aluminium extrusion

PHILIPS
Selecon

SPECIFICATION SUBMITTAL

CONSULTANT <input type="text"/>	PROJECT NAME: <input type="text"/>	MODEL NUMBER QUANTITY: <input type="text"/> <input type="text"/> <input type="text"/> <input type="text"/> <input type="text"/> <input type="text"/>
DATE: <input type="text"/>	PROJECT NUMBER: <input type="text"/>	APPROVED BY: <input type="text"/>

Photometric Data

Tests conducted using standard Philips lamps.

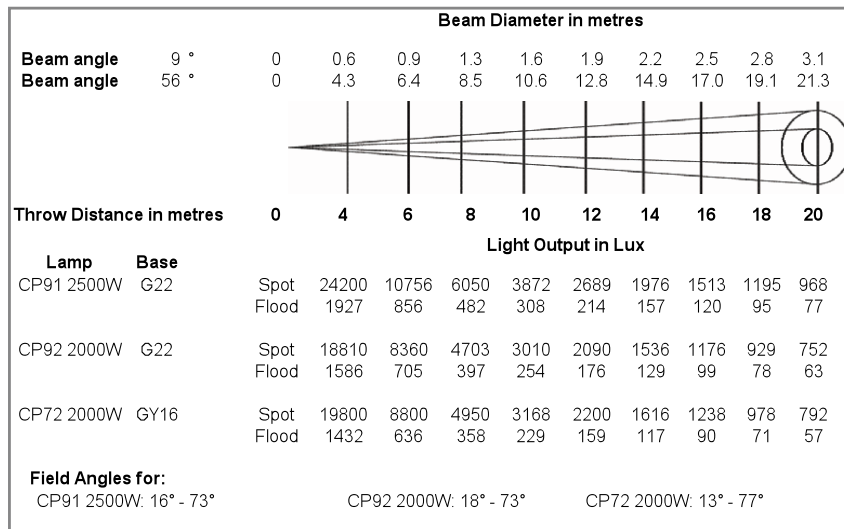

Lamps: 220V-240V

- GY16 lamp socket / 2000w**
- CP72** 50,000 lumens 400 hours average life
- G22 lamp socket / 2500w**
- CP91** 65,000 lumens 400 hours average life
- G22 lamp socket / 2000w**
- CP92** 50,000 lumens 400 hours average life

Approvals

Fully tested and compliant to CE standards

Physical Data

- Weight:** 8.7kg
- Packed Weight:** 11.0kg
- Carton Size:** 310 x 375 x 520
- Carton Size Cubic:** 0.06
- Colour Frame Size:** 245mm x 310mm
- Included:** 1x colour frame, 1x M12 suspension bolt set and instruction sheet.

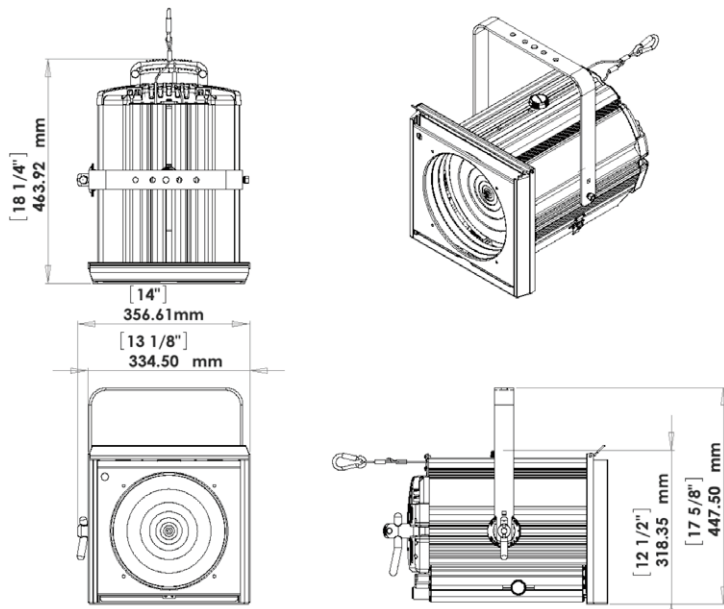

Ordering Information

Cat No Description

10SF2520GY16	Arena H.P. Fresnel - GY16	20SM25	Lens safety mesh
10SF2525G22	Arena H.P. Fresnel - G22	20HC	Suspension hookclamp
20BDSF2025	4 way Barndoor		

Philips Selecon

Los Angeles

6603 Darin Way
Cypress, CA 90630
Tel: (714) 230-8200
Fax: (714) 899-0042

New York

267 5th Ave, 4th Floor
New York, NY 10016
Tel: (212) 213-8219
Fax: (212) 532-2593

Dallas

10911 Petal Street
Dallas, TX 75238
Tel: (214) 647-7880
Fax: (214) 647-8030

www.seleconlight.com

© Philips Group 2009
All rights reserved.
The Company reserves the right to make any variation in design or construction to the equipment described. E&OE

Auckland

19-21 Kawana Street
Northcote, Auckland 0627
New Zealand
Tel: + 64 9 481 0100
Fax: + 64 9 481 0101

Asia

Room 6-10,
20/F Delta House
3 On Yiu Street
Shatin, N.T. Hong Kong
Tel: + 852-2757-3033
Fax: + 852-2757-1767

Europe

European Service & Distribution Centre
Marssteden 152
Enschede 7547 TD
The Netherlands
Tel: +31-53-4500424
Fax: +31-53-4500425

062409EU