



**PROJEKTA 250-RGBAL** is a 240 watts RGBAL image projector. It has a superior optical system, and uniform light spot. Equipped with intelligent electronic zoom system from 15°-30° linearly adjusted. Waterproof IP 65 rating designed all indoor and outdoor professional performance venues.

**SOURCE** Light source: 240 watts RGBAL

**OPTICAL SYSTEM** Optics: 15°-30° Electronic Zoom  
Light output: 90,000Lux @1m @15°

**CONTROL & PROGRAMMING** Rotating Gobo: 1 bi-directional Rotation  
Focus: Motorized linear focus  
Display: On Board Control  
0-25 Hz Strobe  
Control Protocols: DMX, RDM  
Dimmer: 0-100% 16 Bit  
Control Channel: Simple (5CHs), Mode 16 BIT (8CHs)  
Color Mixing : RGBAL

**ELECTRICAL** Input Voltage: AC100-240V  
Max Power: 300 W  
Power Factor: >0.6

**CONNECTIONS** Power connections: 3m cable (input only)  
Data connection: 3m cable (input + output)

**PHYSICAL** Dimensions 648 x 344 x 273 mm  
Net Weight: 15 kg  
Color: Off-White (Gray, Black optional)  
Housing: Die-cast aluminum  
IP Rating: IP66  
Operation temperature: - 20°C~45°C

## Dimensions

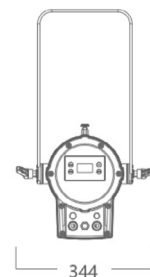
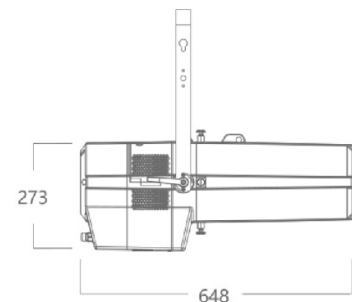

## Luminous Diagram

