



D 200:4L | D 120:4L | D 80:4L



Lab.gruppen D Series: The Integration Superpower

The Lab.gruppen D Series provides exceptional performance and expanded flexibility in high-power audio amplification for challenging systems integration applications in stadia, arenas, convention centers and other large or particularly demanding installed sound installations. Based on the proven, road-tested and green amplifier technologies of Lab.gruppen's renowned PLM Series, the installation-dedicated D Series adds Rational Power Management (RPM™) – a new proprietary Lab.gruppen technology that rationalises power allocation and potentially reduces amplifier inventory. The Lake-variant D Series models benefit from the proven package of onboard

Lake Processing and Dante™ with AES67 digital audio networking, and also offer integration potential with many 3rd party matrix and proprietary DSP systems via dedicated middleware. Equipment specification, commissioning (including configuring RPM and other unique amplifier technologies) and on-going control and system monitoring are managed via the innovative CAFÉ™ software, running on Mac or PC. D Series features include redundant audio inputs as well as on board surveillance and load monitoring to fulfill the requirements of mission-critical voice evacuation compliance.

D Series Features and Benefits

- ▶ Four-channel amplifiers available in three power models
 - ▶ D 200:4 - 20000 W of total output power (4 x 5000 W nominal)
 - ▶ D 120:4 - 12000 W of total output power (4 x 3000 W nominal)
 - ▶ D 80:4 - 8000 W of total output power (4 x 2000 W nominal)
- ▶ Rational Power Management (RPM)
 - ▶ True flexibility in allocating power output across channels to match requirements, enabling more efficient use of amplifier inventory
 - ▶ Any channel is capable of delivering up to 5000 W power output, from total available power in each frame
- ▶ Dedicated on-board surveillance & load monitoring system
- ▶ Unique universal power supply
 - ▶ Regulated Switch-Mode Power Supply (R.SMPST™) maintains stability despite mains voltage fluctuations
 - ▶ Best-in-class Power Factor Correction (PFC)
 - ▶ Current Draw Modelling (CDM™) reduces mains peak draw
 - ▶ Breaker Emulation Limiter (BEL™) - Tailors D Series to the available mains distribution
 - ▶ Under-Voltage Limiting (UVL™) for continued operation despite severe voltage drops
- ▶ CAFÉ (Configuring Amplifiers For the Environment) Software incorporating ESP™ (Equipment Specification Predictor) for design, system and equipment planning, installation and commissioning.

Lake Processing Technologies

- ▶ Lake's exclusive classic/linear-phase/FIR speaker processing platform with four throughputs
- ▶ Group control with Raised Cosine™ MESA EQ™ asymmetric filters
- ▶ LimiterMax™ peak and RMS limiters
- ▶ Extensive loudspeaker preset database (LoadLibrary™)
- ▶ Comprehensive clocking management system with low latency sample rate conversion
- ▶ Full support for Dante Controller
- ▶ Multiple and redundant inputs with programmable failover
 - ▶ Four "Lake Class" analog inputs with Iso-Float™ ground isolation
 - ▶ Two AES3 digital inputs (4 audio channels)
 - ▶ Eight dual-redundant Dante network audio inputs with AES67 support
- ▶ Comprehensive 3rd party protocol for integration potential with 3rd party matrix systems via purpose-developed middleware

D Series: Technology Overview

The D Series from Lab.gruppen offers an unprecedented combination of sustained high output, impeccable sonic performance, configuration flexibility, and real-world efficiencies for reduced installation and operating costs. D Series brings the world's most innovative, capable and proven amplifier technology to virtually any high specification installation project, regardless of preferred DSP platform or specific matrix components.

Proven Lab.gruppen Technologies

Reliability and durability remain the bedrock criteria for any installation amplifier, and in this regard the D Series rigorously maintains Lab.gruppen's industry-leading reputation. The amplifier output stages are the Lab.gruppen patented Class TD[®] which couples the efficiency of Class D topologies to the sonic purity of Class B designs.

Equipped with the Intercooler cooling system, D Series amplifiers dissipate heat more effectively and eliminate "end of tunnel" output device over-temperature problems. D Series also offers a full suite of protection features, including thermal "show-must-go-on" limiting, short circuit protection, excessive average current limiting, sustained VHF (very high frequencies) protection, DC protection and voltage- and current-clip limiting. None of the limiters introduce slow, long term gain changes that can risk altering the balance of a tuned system. A Breaker Emulation Limiter (BEL) prevents power interruption while Under-Voltage Limiting (UVL) allows continued operation despite severe voltage drops.

Rational Power Management (RPM)

At the core of the D Series platform is Rational Power Management (RPM), a proprietary Lab.gruppen technology that gives system designers and integrators unprecedented freedom to allocate the output power available on each channel for optimum performance with specific load conditions. RPM technology also enables the integrator to minimize initial equipment costs, reduce rack space requirement and improve long-term energy efficiency – all without compromising sonic performance.

With conventional installation amplifiers, it is often necessary to "over-specify" amplifiers to meet the maximum power demand on one channel, leaving excess power capacity wasted on the remaining channels. RPM reduces costly excess capacity by allowing re-allocation of output power capacity among the four channels. RPM can be configured so that any channel can supply up to 5000 W regardless of power model. With RPM in the D Series, the maximum output channel(s) can be used for power-hungry low-frequency

systems while the remaining output power can be allocated as needed for the mid-frequency and high-frequency drivers, or for less demanding zones within a typical large project – such as concessions, concourses, VIP suites and function rooms within a sports arena or stadium.

From within the CAFÉ software, RPM allows the desired power demand to be specified for the different loads in several different ways. RPM then analyses the desired power in relation to different channel and device constraints. If all desired power levels are within constraints, RPM safeguards the balance and assures that the specified output power will be maintained regardless of demand of other channels. If a particular zone's input is being driven beyond the specified power levels, RPM aids in limiting that zone to make sure the power is available for other zones. If the desired total power is in excess of what the power model can deliver, RPM can facilitate that the limitation is shared equally among the channels.

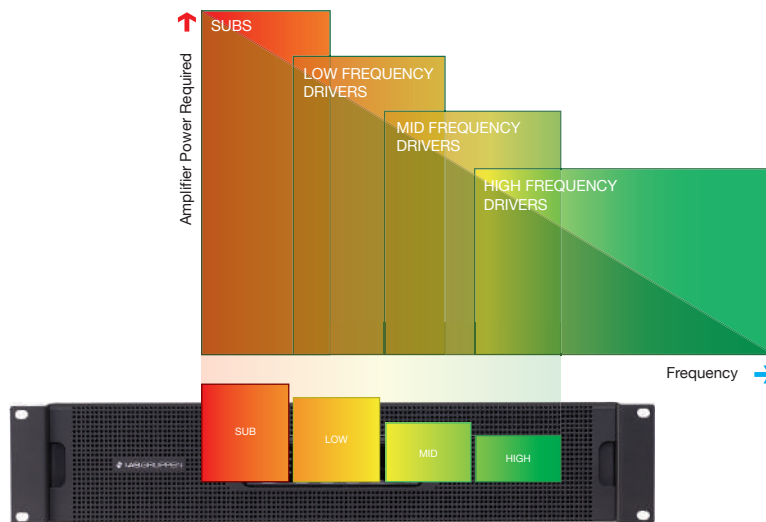

D Series - Amp channels power adjusted to match the loudspeaker requirements

CAFÉ and RPM for Green Credentials

D Series is configured and monitored using Lab.gruppen's CAFÉ (Configuring Amplifiers For the Environment) software suite. In addition to providing comprehensive system surveillance and configuration of RPM and other amplifier features such as ISVPL and Breaker Emulation Limiter (BEL), CAFÉ also includes valuable help to save the environment. In combination with the RPM configuration CAFÉ can accurately predict, based on the true SPL and speaker requirements of the individual loads for the given project, estimations of average mains current draw and generated heat in BTU. With D Series' innovative power supply technologies (true Power Factor

Correction utilizing Current Draw Modelling) the required mains draw is already best in class in relation to burst power output, but in combination with the BEL the mains draw can also be safeguarded to the predicted level. The end result is precise mains management and thermal control, which allows more accurate (rather than over-specified) provision of mains distribution, cabling and cooling. This technology suite not only saves on installation costs, it also reduces lifetime running costs and minimizes environmental impact. It also reduces demands on UPS systems in "mission critical" voice evacuation systems in arenas and stadia.



CAFÉ and Equipment Specification Predictor (ESP)

CAFÉ also features an innovative design aid – the Equipment Specification Predictor (ESP). ESP examines the system SPL and speaker requirements for a given project and aids in transforming that data into circuit and amplifier channel requirements. On a system

level, ESP supplies a recommendation for optimized placement of channels into amplifiers for the most cost effective solution. The recommendation includes model and quantities of D Series required with most rational use of amplifiers, minimizing wasted headroom.

Speaker outputs

Detachable terminal block connectors for easy install (up to 16 mm² or 6 AWG cables)

Two AES3 digital inputs (4 audio channels)

32 amp locking powerCON for mains supply

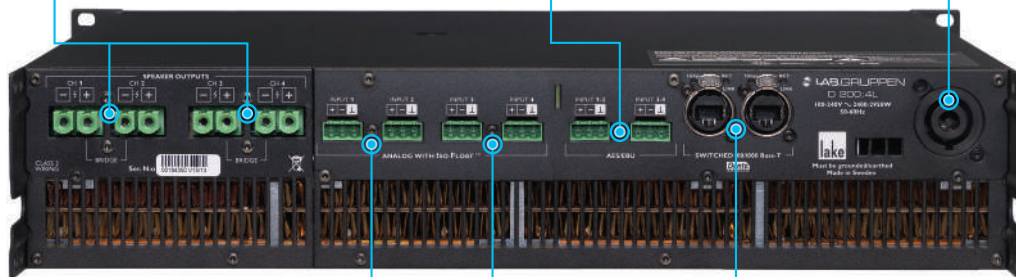

Analog inputs with Iso-Float

Four "Lake class" analog inputs with Iso-Float ground isolation

EtherCON inputs

Two etherCON jacks are provided for the dual redundant control and Dante connections

LAB.GRUPPEN

WWW.LABGRUPPEN.COM

Lake Processing

D Series Lake versions provide extraordinary input flexibility, the legendary power of exclusive Lake processing algorithms, comprehensive control and load monitoring via Lake Controller, and seamless integration into Dante digital audio networks with AES67 support. In addition, by employing third-party middleware, D Series Lake versions can be integrated into on other widely used networked digital matrix systems.

All three D Series Lake models incorporate four full-featured Lake Processing modules, with four discrete channels of audio throughput input to output. Audio signals are selectable from four channels of analog (with Iso-float ground isolation), four channels via AES3 digital inputs and eight dual redundant Dante networked digital inputs. Input signals are individually selectable for each channel, with programmable failover to to a lower prioritized input.

The full-featured, on-board Lake processor includes group control with Raised Cosine MESA EQ asymmetric filters to match the responses of many loudspeaker systems. LimiterMax peak and RMS limiters set the industry standard for loudspeaker protection and sonic transparency.

The included Lake Controller software provides a unified interface for control of Lake functions and for comprehensive monitoring of both amplifier status and connected loudspeaker loads. Optimized for a wireless tablet PC, Lake Controller is easy and intuitive to operate, with the “feel” of real-time analog faders and controls. Lake Controller also features seamless integration with third party, real-time sound system measurement, optimization, and control software packages. Users can measure spectrum and transfer function and adjust system EQ at the same time, using the same user interface.

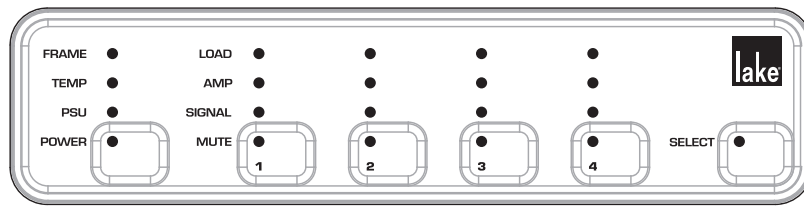

Front Panel: Lake Versions

The front panel provides controls for power STANDBY/ON and for amplifier channel mute as well as bidirectional select functionality between device and software. It also includes multi-color LED

indicators which display important status information for the D Series Lake platform unit as well as for each individual output channel.

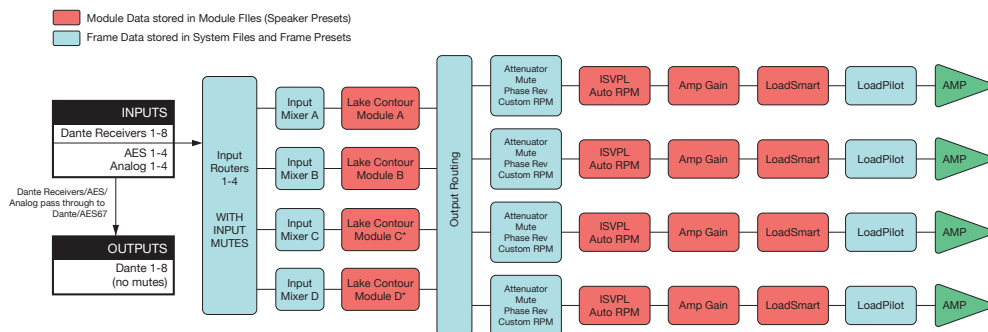

System Block

The input section (inputs, input router and input mixer) allows for mixing capabilities as well as redundant and prioritized inputs with automatic switch-over in case of signal failure. Up to four Lake Processing modules provide user EQ and loudspeaker processing,

including LimiterMax limiting. Each power output channel provides individual channel processing, including ISVPL limiter, RPM and load monitoring.

Specifications

	D 200:4L	D 120:4L	D 80:4L
General			
Processing / Network	Lake / Dante	Lake / Dante	Lake / Dante
Number of amplifier channels	4	4	4
Total burst power all channels (share among channels with RPM)	20000 W	12000 W	8000 W
Max. Output Power (all ch.'s driven) ¹⁾			
2 ohms	4400 W	3000 W	2000 W
2.67 ohms	5000 W	3000 W	2000 W
4 ohms	4400 W	3000 W	2000 W
8 ohms	2300 W	1900 W	1500 W
16 ohms	1150 W	950 W	750 W
Hi-Z 70 V	3300 W	3000 W	2000 W
Hi-Z 100 V	4700 W	3000 W	2000 W
Max. Output power bridged mode (all ch.'s driven) ¹⁾			
4 ohms	8800 W	6000 W	4000 W
8 ohms	8800 W	6000 W	4000 W
16 ohms	4600 W	3800 W	3000 W
Max output power single channel (all models) ¹⁾			
2 ohms	4400 W		
2.67 ohms	5900 W		
4 ohms	4600 W		
8 ohms	2300 W		
16 ohms	1150 W		
Hi-Z 70 V	3300 W		
Hi-Z 100 V	4700 W		
Amplifier output modules (all models, all channels)			
Peak output voltage	194 V		
Max output current	67 A		
Rational Power Management (RPM)	Share "total burst power" of the product freely among channels. Any channel can scale up to the "Max. output power single channel"		
Default voltage limitation (can be lifted with RPM configuration)	194 V	175 V	155 V
Protection features	Current Average Limiter (CAL), Very High Frequency Protection (VHF), Direct Current Protection (DC), Short Circuit Protection, Current-Clip Limiter, Voltage Clip Limiter, Temperature protection		
Amplifier platform			
Inter Sample Voltage Peak Limiter (ISVPL)	Configurable Peak voltage threshold and profile		
Amplifier gain	Digital configurable amplifier gain 22 - 44 dB		
Pilot tone generation and analysis	LoadPilot		
Load impedance analysis	Yes		
Temperature control	Regulated fans and show must go on limitation (ATL, PTL)		
Audio Performance (Amplifier platform with digital input)			
THD + N 20 Hz - 20 kHz for 1 W	< 0.05 %		
THD + N at 1 kHz and 1 dB below clipping	< 0.04 %		
Dynamic range	> 114 dB		
Channel separation (Crosstalk) at 1 kHz	> 70 dB		
Frequency response (1 W into 8 ohm, 20 Hz - 20 kHz)	+/- 0.05 dB		
Internal sample rate / Data path	48 / 96 kHz / 32 bit floating point		
Product propagation delay AES 96 kHz / analog input	1.61 / 1.68 ms		
Lake processing			
Loudspeaker processing	Up to 4 modules of Classic/linear-phase/FIR crossover, EQ, delay, LimiterMax™ - peak and RMS limiters		
System tuning	Group control with Raised Cosine™ MESA EQ™ asymmetric filters		
Input redundancy / Matrix	Automatic 4 level input redundancy / 4 input mixers		
System integration	Comprehensive 3rd party protocol over UDP Ethernet		
Dante Audio Network			
Dante I/O	8 x 8 (shared with AES67)		
Network topology / redundancy	Flexible topology / Supports daisy-chained and Dual redundant networks		
Sample rates / transport	48, 96 kHz / Uni + Multicast		
Network latency	0.25, 0.5, 1.0, 2.0, 5.0 ms		
AES67 Audio Network			
I/O	8x8 (shared with Dante)		
Network topology / redundancy	Flexible topology / supports daisy-chained networks		
Sample rates / transport	48 kHz / Multicast		
Network latency	2 ms		
Analog inputs			
Inputs	4 high quality inputs with Iso-Float ground isolation		
Maximum input / digital reference	+ 26 dBu / +21 dBu		
Sampling rate / resolution	96 kHz / 24 bit		
Input impedance balanced / unbalanced	20 / 10 kOhm		
THD + N (typical at 1 kHz unweighted)	0.00022 %		
THD + N (typical at 20 Hz and 20 kHz unweighted)	0.00033 %		

Specifications

	D 200:4L	D 120:4L	D 80:4L
AES Inputs			
Inputs	2 AES inputs (4 audio channels)		
Supported sample rates / resolution	44.1, 48, 88.2, 96, 176.4, 192 kHz / up to 24 bit		
Sample rate conversion THD + N 20 Hz - 20 kHz unweighted	0.00003 %		
Rear panel interface			
Analog inputs	4 x Terminal block connectors along input with +, - and ground		
AES inputs	2 x Terminal block connectors		
Output connectors	4 x 2 pole Terminal block connectors rated at 1000 V / 76 A (exceeding amplifier capacity) Can take up to 16 mm ² (6 AWG) cables		
Ethernet ports	2 x EtherCon RJ45 100/1000 Base-T for the Lake Controller, Dante controller and/or DLM (3rd party protocol)		
Detachable mains cord	Neutrik PowerCon rated at 250 V / 32 A		
Front panel user interface			
System status indication	3 x tri-color LED. FRAME, TEMP, PSU for device status indication		
Channel status indication	3 x tri-color LED per channel. Status indication separated for channel LOAD, AMP, SIGNAL status		
Mute	Per channel touch button for MUTE control and tri-color LED for indication		
Power	Touch button for ON/STANDBY control and tri-color LED for power state indication		
Select	Touch button and LED for bi-directional device software select functionality		
Mains Power			
Nominal voltage	100 – 240 V AC 50 – 60 Hz		
Operating voltage	70 – 265 V AC 45 – 66 Hz		
Mains wall plug	Selectable on order CEE 7/7 "Schuko" 230 V / 16 A, NEMA L5-30 "Twistlock" 125 V / 30 A, NEMA 5-15P 125 V / 15 A (D 80:4 only), NEMA 5-20P 125 V / 20 A (D120:4 only), NEMA 6-20P 250 V / 20 A, AS/NZS 3112 230 V / 15 A (Aus/Nz), BS 546 230 V / 16 A (India), C-30P 125V / 30A (Japan)		
Power supply features			
Soft start / Inrush power	Yes / Max 8 A		
Power factor correction	> 0.98 for mains power > 400 W		
Regulated switch mode power supply (R.SMPS)	Yes		
Breaker Emulation Limiter (BEL)	Configurable current threshold and breaker profile		
BEL max current threshold	32 A	25 A	15 A
Power Average Limiter (PAL)	Yes		
Under Voltage Limiter (UVL)	Yes		
Mains undervoltage and overvoltage protection and mains glitch tolerance	Yes		
Dimensions			
Rack rail to rear panel	W: 483 mm (19"), H: 88 mm (2 U), D: 424 mm (16")		
Overall all depth front-rear support	D: 463 mm		
Weight			
	16.5 kg (36 lbs)	15.8 kg (35 lbs)	14.5 kg (32 lbs)
Finish			
	Black painted steel chassis with grey painted steel front with detachable grille		
Approvals			
	CE, ETL (ANSI/UL, CSA), PSE, RCM		

Note 1): Lab.gruppen burst power (1 kHz, 25 ms burst power @ 150 BPM, 12 dB Crest factor)

All specifications are subject to change without notice.